

Kingpin Bushing and Seal Installation Instructions

MODELS:

E-1000I	E-1200I	E-1320I	E-1460I	EFA-12F3, EFA-12F4	EFA-22T2
E-1000W	E-1200W	E-1320W	E-1460W	EFA-13F3, EFA-13F5	EFA-22T5
	E-1201W		E-1462I	EFA-18F3, EFA-20F4	EFA-24T2
					EFA-24T5
D1001IL	D1251IL	D1401I	E1252IL		
D1001LW	D1251LW	D1401I	E1252LW		
D1201IL	D1301IL	D1461I			
D1201LW	D1301LW	D1461IL			
D1231IL	D1321IL	D1461W			
D1231LW	D1321LW				

Some Dana bushings require reaming after installation. This kit contains “pre-sized” kingpin bushings that do not require reaming. Follow the proper installation instructions provided with the parts.

Below are the installation instructions for kingpin bushing and seal replacement only. Refer back to the proper service manual for detailed instructions on the disassembly and assembly of all other steer axle components.

Installation Steps:

1. Remove the old grease seals from the knuckle kingpin bores with a suitable tool.
2. Drive bushings out of knuckle with the proper removal/installation tool.
3. Remove all foreign material from kingpin areas of the steering knuckle and axle beam.
4. Wire brush machined surfaces, taking care not to damage them. Clean kingpin bore.
5. When installing the bushings, lightly lubricate the outside diameter to make installation easier.
6. Hand start the bushing in the beam bore.

Note: When installing kingpin bushings, position the seam in areas marked “X” (See Figure 1)

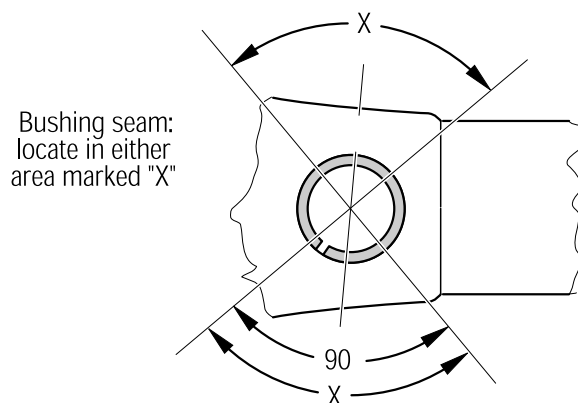

Figure 1

Kingpin Bushing and Seal Installation Instructions (cont.)

7. Drive bushing until they are located at the depth indicated on Figure 2. Use the same method to install both top and bottom bushings.

Steer Axle Model	Bushing Depth
D-600N, D-700F, D-700N, D-800F, D-800W	.17" (4.3 mm) Top .56" (14.2 mm) Bottom
D-2000F, D2200F	.55" (14.0 mm)
E-1002O, E-1002LW, E-1002OW, E-1252L, E-1252O, E-1252LW, E-1252OW, E-1322L, E-1322LW	.55" (14.0 mm)
E-1000I, E-1002I, E-1200I, E-1202I, E-1320I, E-1322I, E-1201I, E-1203I, E-1460I, E-1462I	.55" (14.0 mm)
E-1000W, E-1002W, E-1200W, E-1202W, E-1320W, E-1322W, E-1460W, E-1462W	.55" (14.0 mm)
E1002C, E1202C, E1202CW, E1322C, E1322CW, E1462C, E1462CW	.69" (17.5 mm) Top .55" (14 mm) Bottom
EFA Family	.25" (6.4 mm)
I-100W, I-120W, I-130W, I-140W, I-160W, I-180W, I-200W, I-220W	.20" (5.1 mm)
I-130SG, I-132SG, I-140SG, I-160SG, I-180SG	.20" (5.1 mm)
I-60SG, I-80SG	.17" (4.3 mm) Top .34" (8.6 mm) Bottom
I-100SG, I-100SGL, I-120SG, I-120SGL	.40" (10.2 mm) Top 1.12" (28.4 mm) Bottom

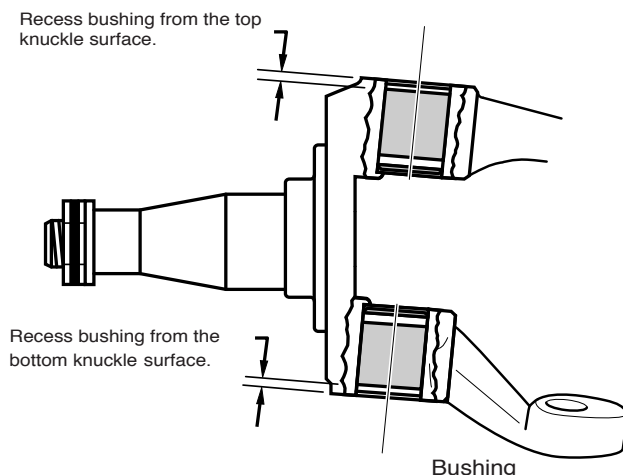

Figure 2

8. Install new grease seal using the proper installation tool. When installing the seal, be sure the lip is pointing toward the center of the knuckle. See Figure 3 for seal position.

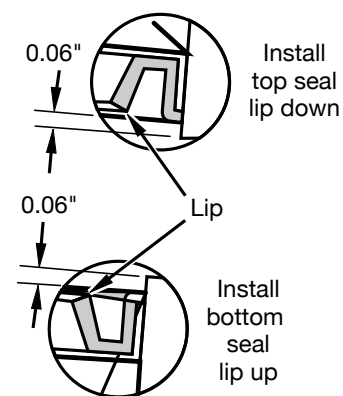

Figure 3

For spec'ing or service assistance, call 1-800-621-8084 24 hours a day, 7 days a week, or visit our web site at SpicerParts.com

SpicerParts.com

Dana Aftermarket Group

PO Box 1000 Maumee, Ohio 43537

Warehouse Distributors: 1.800.621.8084

OE Dealers: 1.877.777.5360

Follow SpicerParts [f](#) [t](#) [@](#) [in](#)

© 2020 Dana Limited. All rights reserved. SHAIS130

SPICER[®]

